

Ultra mills



Ultra mills

🇬🇧 Ultra Mills, made of powder HSS, can meet the highest requirements whenever the use of solid carbide end mills is not allowed.

🇮🇹 La linea di fresatura Ultra Mills in HSS sinterizzato soddisfa le esigenze di alto rendimento in tutte le applicazioni in cui l'utilizzo del metallo duro non sia consentito.

🇩🇪 Die Ultra Mills Produktpalette wird aus gesintertem HSS hergestellt. Sie befriedigt damit alle Bedürfnisse der Anwendungen, wo Vollhartmetall nicht verwendet werden kann.

🇫🇷 La gamme de fraisage Ultra Mills, en acier fritté, satisfait toutes exigences de haute performance quand l'utilisation du carbure n'est pas possible.



PV200 COATING
POWDER STEEL

HIGH PERFORMANCE · ALTO RENDIMENTO
HOCHLEISTUNG · HAUTE PERFORMANCE

n **Vf**
PAGE
260-261

DIN
327

UMWS2 - UMWS3 (e8)

Ø mm	1~3	4~6	7~10	12~18	20~25
tol. D µ	-14 / -28	-20 / -38	-25 / -47	-32 / -59	-40 / -73



UMWS2

UMWS3

Z2

HSS-P

PV200

UM

30°

Z3

HSS-P

PV200

UM

30°

D(e8)	d(h6)	l	L	Stock	Stock
mm 2	6	4	48	○	○
3	6	5	49	●	●
4	6	7	51	●	●
5	6	8	52	●	●
6	6	8	52	●	●
7	10	10	60	○	○
8	10	11	61	●	●
9	10	11	61	○	○
10	10	13	63	●	●
12	12	16	73	●	●
14	12	16	73	●	●
16	16	19	79	●	●
18	16	19	79	●	●
20	20	22	88	●	●

● stock standard ○ non-standard stock EX stock exhaustion



 PAGE 262

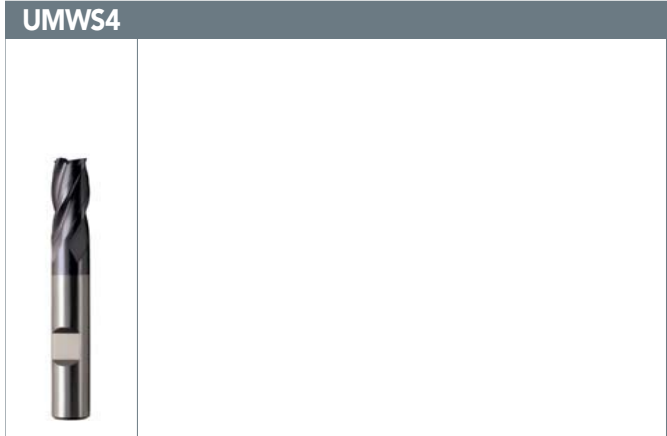



DIN
844

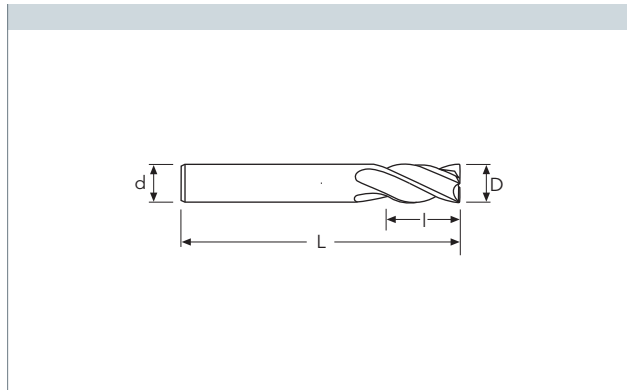

UMWS4

Ø mm	1-20
tol. D µ	0 / +30



 Z4
 HSS-P
 PV200
 UM
 30°

D	d(h6)	l	L	Stock
mm 3	6	8	52	●
4	6	11	55	●
5	6	13	57	●
6	6	13	57	●
7	10	16	66	○
8	10	19	69	●
9	10	19	69	○
10	10	22	72	●
12	12	26	83	●
14	12	26	83	●
16	16	32	92	●
18	16	32	92	●
20	20	38	104	●

● stock standard ○ non-standard stock EX stock exhaustion

n **Vf**
PAGE
262-263

DIN
844

UMWSFR



UMWSFR (js12)

Ø mm	3~6	7~10	12~18	20~25
tol.D µ	±60	±75	±90	±105

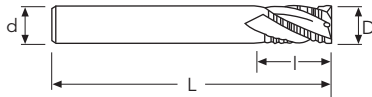

D(js12)	d(h6)	l	L	Z	Stock
mm 6	6	13	57	3	●
7	10	16	66	3	●
8	10	19	69	3	●
9	10	19	69	3	●
10	10	22	72	4	●
12	12	26	83	4	●
14	12	26	83	4	●
16	16	32	92	4	●
18	16	32	92	4	●
20	20	38	104	4	●

● stock standard ○ non-standard stock EX stock exhaustion